

# COMPRESSION GAS SPRINGS

WITH A PISTON DIAMETER OF 6 mm ENDED WITH M6 THREADS

Compression gas springs are a multipurpose product of a simple cylindrical shape with different mounting variants producing an extending power under pressurized nitrogen. The compression of the piston into the cylinder compresses nitrogen, resulting in the formation of force, which extends the piston from the cylinder. The amount of force depends on the cross section of the piston rod, the cylinder volume and the amount of nitrogen therein.

Gas springs are finished with an M6 thread, for which there is a wide range of end fittings. End fittings for this type of spring can be found in many material versions.

The piston rod is made of C35 steel, which is treated by nitriding (QPQ). The cylinder body is made of ST34 2-BK steel and painted with black epoxy paint.

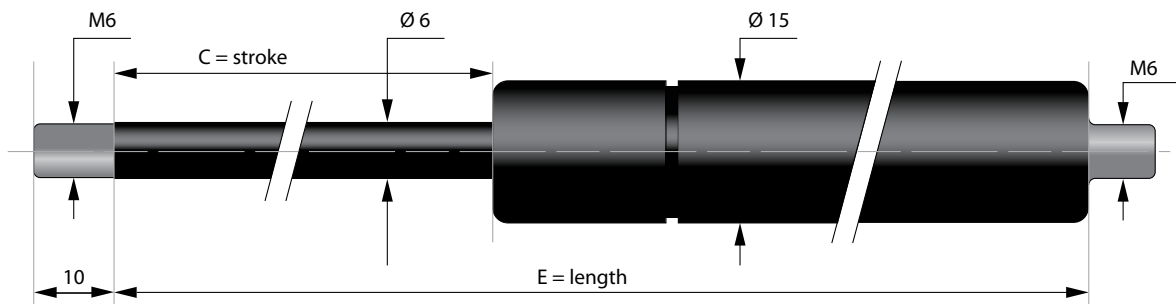

C - stroke [mm]	E - length [mm]	F1 - force [N]	Reference
20	80	30-250	ST 020+F1 V+D6
40	115	30-400	ST 040+F1 V+D6
60	155	30-400	ST 060+F1 V+D6
80	195	30-400	ST 080+F1 V+D6
100	225	30-400	ST 100+F1 V+D6E225
100	235	30-400	ST 100+F1 V+D6
120	275	30-400	ST 120+F1 V+D6
150	335	30-400	ST 150+F1 V+D6

Instructions for ordering the correct type of gas springs:

If you need a gas spring with a piston diameter of 6 mm, finished M6 thread, stroke of C = 100mm and with a force of F1 = 200N – the spring will have order number ST100 200 VD6.

## FUNCTION DIAGRAM FOR COMPRESSION GAS SPRING

