

COMPRESSION GAS SPRINGS

WITH A PISTON DIAMETER OF 8 mm ENDED WITH M6 THREADS

Compression gas springs are a multipurpose product of a simple cylindrical shape with different mounting variants producing an extending power under pressurized nitrogen. The compression of the piston rod into the cylinder compresses nitrogen, resulting in the formation of force, which extends the piston from the cylinder. The amount of force depends on the cross section of the piston rod, the cylinder volume and the amount of nitrogen therein.

Gas springs are finished with an M6 thread, for which there is a wide range of end fittings. End fittings for this type of spring can be found in many materials versions.

The piston rod is made of C35 steel, which is treated by nitriding (QPQ). The cylinder body is made of ST34 2-BK steel and painted with black epoxy paint.

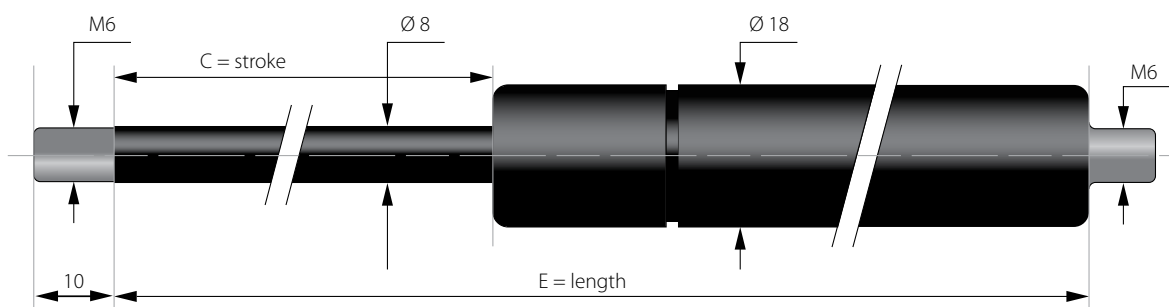

C - stroke [mm]	E - length [mm]	F1 - force [N]	Reference
40	125	50-750	ST 040+F1 V+D8
60	165	50-750	ST 060+F1 V+D8
70	183	50-750	ST 070+F1 V+D8
80	205	50-750	ST 080+F1 V+D8
89	268	50-750	ST 089+F1 V+D8
90	225	50-750	ST 090+F1 V+D8
100	245	50-750	ST 100+F1 V+D8
120	285	50-750	ST 120+F1 V+D8
140	325	50-750	ST 140+F1 V+D8
160	365	50-750	ST 160+F1 V+D8
180	405	50-700	ST 180+F1 V+D8
200	445	50-700	ST 200+F1 V+D8
220	485	50-700	ST 220+F1 V+D8
250	545	50-700	ST 250+F1 V+D8
250	600	50-700	ST 250+F1 V+D8E600
300	645	50-700	ST 300+F1 V+D8

Instructions for ordering the correct type of gas springs:

If you need a gas spring with a piston diameter of 8 mm, finished M6 thread, stroke of C = 100mm and with a force of F1 = 600N – the spring will have order number ST100 600VD8.